

# TEV-385-50

## The Energy saving Ventilator



### ENERGY CONSERVATION

PlymoVent's mission is to design energy efficient products. PlymoVent utilises as standard equipment Energy Efficient Motors. This standard in conjunction with our new design produces the lowest operating cost fan package offered in the world today. If you have an existing fan, you can replace it with a PlymoVent and reduce your operating costs and in turn receive a return on your investment. Not many other products can stand behind that claim.

### POWER CONSUMPTION

PlymoVent fans require less kW versus air volume delivered. This does not only equate to less power consumption but also less installation cost. This allows the electrical installer to reduce the cost of installation by reducing the associated components required to run the motor.

### EASY ACCESS IMPELLER

All PlymoVent fan housings are designed for easy access to the impeller. Our design allows an installer or service technician to remove the motor and impeller wheel without removing inlet or outlet ductwork or disassembling the fan housing. It also provides the installer the option of separating the fan into two pieces when mounting in confined locations above drop ceilings or tight access ways.

### AIRFOIL IMPELLER

PlymoVent in co-operation with an internationally recognized university, has designed the ultimate airfoil fan impeller. Through the use of aerospace design techniques, PlymoVent has been successful in designing a fan impeller that maximises air delivery at higher static pressures and reduces energy consumption at the same time. PlymoVent fans deliver the air volume you need at 30% less energy required over any competitive fan.



	mm	inches
A	640	25 3/16
B	640	25 3/16
C	230	9 1/16
D	160	6 5/16
E	160	6 5/16
F	254	10
G	453	17 13/16
H	355	13 31/32
I	288	11 11/32
J	373	14 11/16
K	267	10 1/2

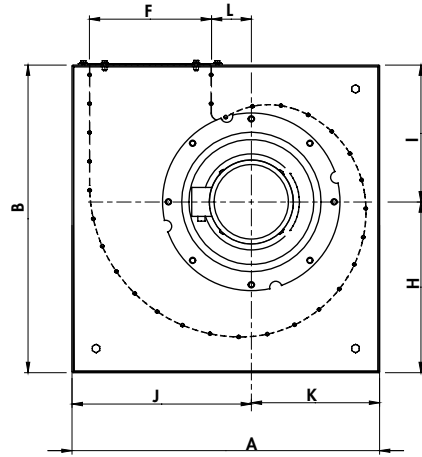
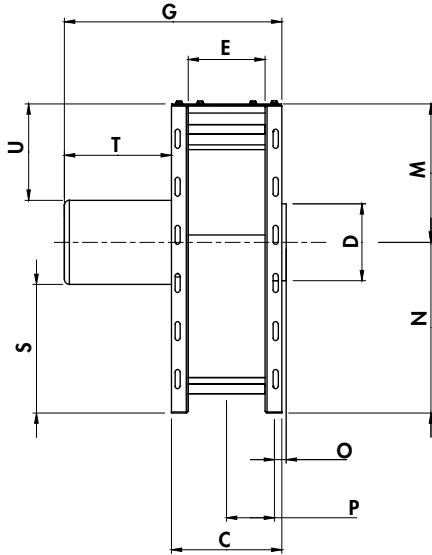

	mm	inches
L	83	3 9/32
M	288	11 11/32
N	355	13 32/32
O	25	1
P	99	3 15/16
Q	-	-
R	-	-
S	268	10 17/32
T	223	8 3/4
U	201	7 29/32

TECHNICAL DATA

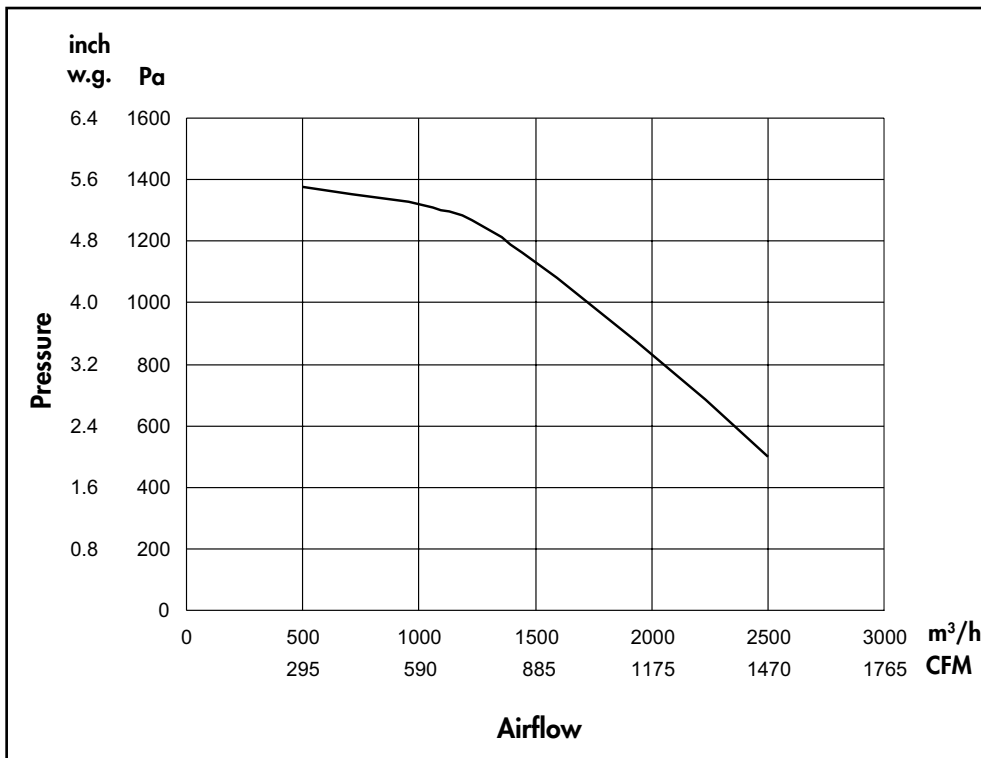

Fan specifications

- Construction: AMCA Type - B
- Drive type: Direct drive
- Impeller type: Backward incline
- Impeller material: Aluminium
- Impeller diameter: 315 mm / 12.4 inch
- Impeller width: 85 mm / 3.35 inch
- Hub size: 19 mm / 0.75 inch
- Discharge style: Rotational 90°
- Shaft seal: Rubber
- Housing material: Galvanized steel
- Housing finish: Epoxy powder coat
- Total fan weight: 31 kg / 68 lbs

Motor specifications

- Frame size: IEC IA801-2
- Shaft size: 19 mm / 0.75 inch
- Motor: 0.75 kW
- Motor RPM: 2874 rpm
- Service factor: 1.15
- Thermal protection: No
- CE-listed: Yes

Electrical power is available for all international electrical power sources.

Measurement in accordance with SS ISO-5801.

SOUND POWER DATA

Octave Band (Hz)	63	125	250	500	1000	2000	4000	LwA
Sound power (dB)	68.7	72.7	78.4	73.4	76.9	69.7	64.6	79.3

The sound power measurement in accordance with SS ISO-5135.



PlymoVent representative

