

# MF-30

– Mechanical Filter, wallmounted,  
for two PlymoVent Ø 160 mm / 6.3" KUA/EA-arms

## TECHNICAL DATA

### Unit specification

Housing material: Galvanized steel  
Housing finish: Epoxy powder coat  
Unit weight: 49 kg / 108 lbs  
Unit dimensions: H: 857 mm / 33 3/4 inch  
W: 680 mm / 26 3/4 inch  
D: 763 mm / 30 inch  
Air volume: 2 x 800 - 1200 m<sup>3</sup>/h / 2 x 470 - 700 CFM  
Max. negative pressure: 4000 Pa / 16" wg  
Filter indicator: Manometer 0-2000 Pa / 0-8" wg

### Filter elements:

Stage 1: Spark arrestor  
Stage 2: Pre-filter aluminium mesh  
Stage 3: Fine filter, glass fibre – GFMF  
95% ASHRAE/F9 EuroVent/BIA-C  
Final filter pressure: 800 Pa / 3.2" wg

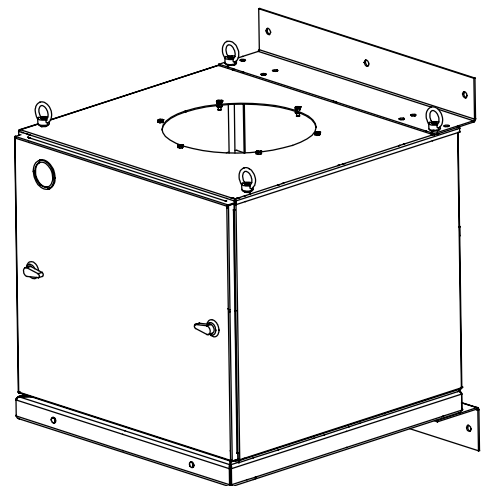

## DIMENSIONAL DATA

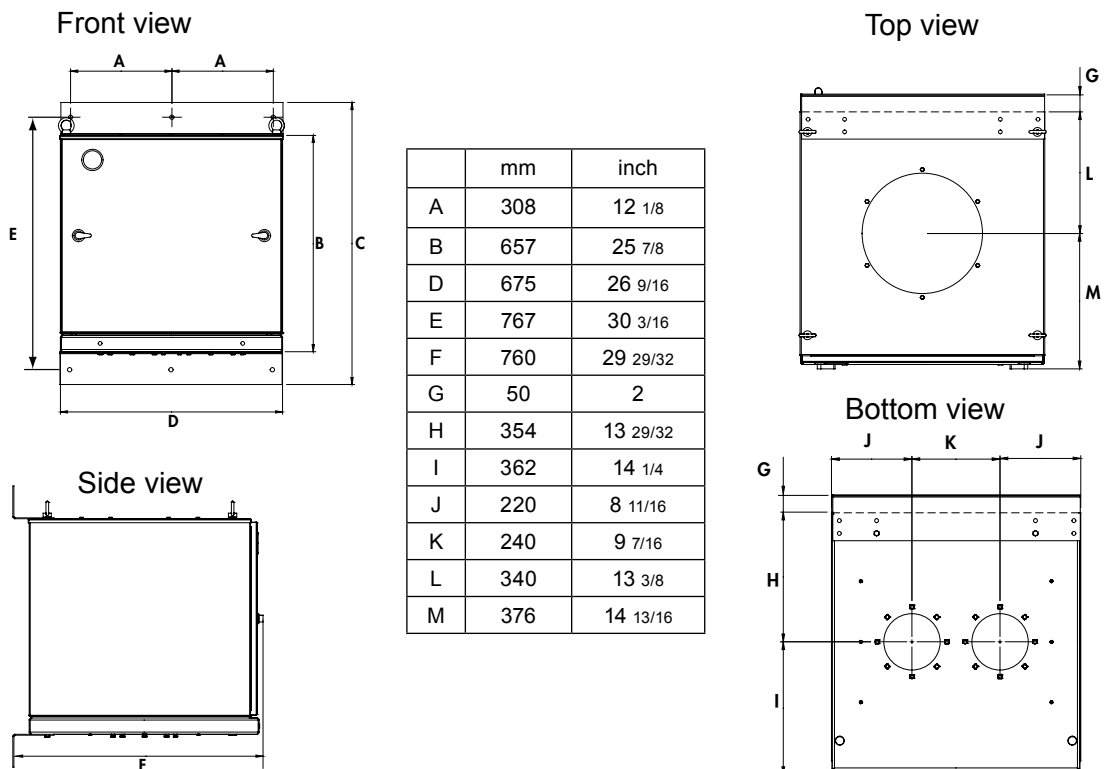

PlymoVent representative



## PLYMOVENT®

PlymoVent AB  
Industrigatan 26,  
SE-212 14 Malmö, Sweden  
Tel: +46 40 30 31 30,  
Fax: +46 40 30 31 40  
www.plymovent.com  
info@plymovent.se

PlymoVent Ltd  
Marley Way, Southam Road, Banbury,  
Oxfordshire OX16 2RA, England  
Tel: (01295) 25 93 11,  
Fax: (01295) 27 17 50  
www.plymovent.co.uk  
info@plymovent.co.uk