

KUA-200

FLEXIBLE EXTRACTION ARM

The KUA-200 is a flexible extraction arm with an external middle hinge. The removable hood has a safety mesh. The arm is fitted with a sealed shut-off & control valve and is 360° rotatable.

The KUA-200 arm is available in three different types:

- type **H**: for hanging mounting (wall bracket included)
- type **S**: for standing mounting (future development)
- type **ATEX**: approved for use in explosive environments Zone 22; marking EX II 3D (for hanging mounting only)



APPLICATIONS

The KUA-200 is intended to be used for the following applications:



- MIG-MAG/GMAW welding
- TIG welding
- FCAW welding
- stick/MMAW welding
- grinding
- polishing
- finishing

SPECIFICATIONS

Physical dimensions and properties

Diameter:	<ul style="list-style-type: none"> • tubes: Ø 200 mm (7.9 in.) • hood opening: Ø 340 mm (13.4 in.)
Material of tubes	aluminium
Colour:	<ul style="list-style-type: none"> • tubes: yellow RAL 1004 • hoses: black

Performance

Recommended airflow: max. 1600 m³/h (940 CFM)

Ambient and process conditions

Process temperature:	<ul style="list-style-type: none"> • min.: 5°C (41°F) • nom.: 20°C (68°F) • max.: 70°C (158°F)
Max. relative humidity	90%
Outdoor use allowed	no
Storage conditions	<ul style="list-style-type: none"> • 5-45°C (41-113°F) • relative humidity max. 90%

Options and accessories

LL-5.5/24-200	manual on/off switch, incl. LED working light
Arm-fan adapter KUA-FUA	for connection of fan type FUA-1800/ 2100/3000

Product combinations

KUA-200/3H | 4H (incl. ATEX versions)

FUA-1800 FUA-2100 FUA-3000	extraction fan
FlexMax: FM-15/200 FM-25/200 FM-35/200 FM-45/200	extension crane
PA-110/200 PA-220/200	stanchion

Scope of supply

- H types: extraction arm (in parts) – Wall bracket
- S types: extraction arm (in parts)

Order information

Number/package: 1

Shipping data

Harmonized Tariff Code: 84219990

WORKING REACH

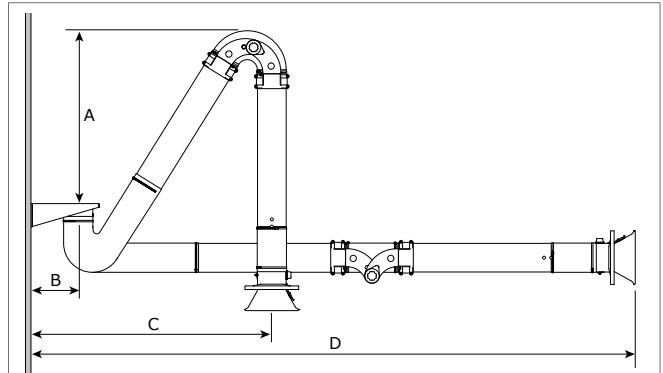

	KUA-200/3H		KUA-200/4H	
	mm	ft	mm	ft
A	1150	3.8	1450	4.8
B	345	1.1	345	1.1
C	min. 1450	min. 4.8	min. 1620	min. 5.3
D	max. 3440	max. 11.3	max. 4130	max. 13.5

Remaining specifications

Type	KUA-200/3H	KUA-200/4H	KUA-200/3H ATEX	KUA-200/4H ATEX	KUA-200/3S	KUA-200/4S
			Extraction arm in accordance with: TRGS 727 & ATEX directive 94/9/EC			
■ Physical dimensions and properties						
Material of hoses	PVC with spring steel wire		polyethylene with copper coated spring steel wire		PVC with spring steel wire	
Length	3 m (9.8 ft)	4 m (13.1 ft)	3 m (9.8 ft)	4 m (13.1 ft)	3 m (9.8 ft)	4 m (13.1 ft)
Weight (net)	36 kg (79 lbs.)	37 kg (82 lbs.)	39 kg (86 lbs.)	41 kg (90 lbs.)	27 kg (60 lbs.)	28 kg (62 lbs.)
■ Order information						
Art. no.	0000112775	0000112776	0000113756	0000113757	0000112877	0000112878
■ Shipping data						
Gross weight	42 kg (93 lbs.)	43 kg (95 lbs.)	41 kg (90 lbs.)	43 kg (95 lbs.)	33 kg (73 lbs.)	34 kg (75 lbs.)
Packing dimensions	1740 x 355 x 660 mm (68.5x14x26 in.)	2085 x 355 x 660 mm (82x14x26 in.)	1740 x 355 x 660 mm (68.5x14x26 in.)	2085 x 355 x 660 mm (82x14x26 in.)	1740 x 355 x 660 mm (68.5x14x26 in.)	2085 x 355 x 660 mm (82x14x26 in.)

MOUNTING POSSIBILITIES "H" TYPES

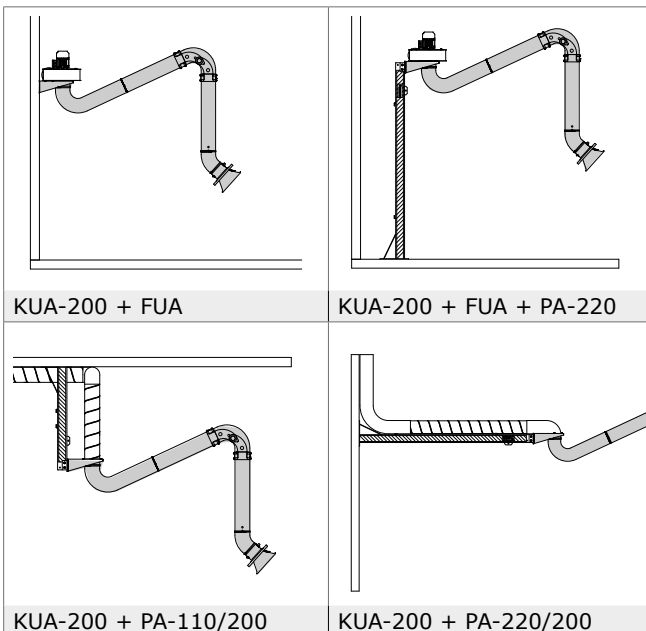

FEATURES & BENEFITS



PRESSURE DROP

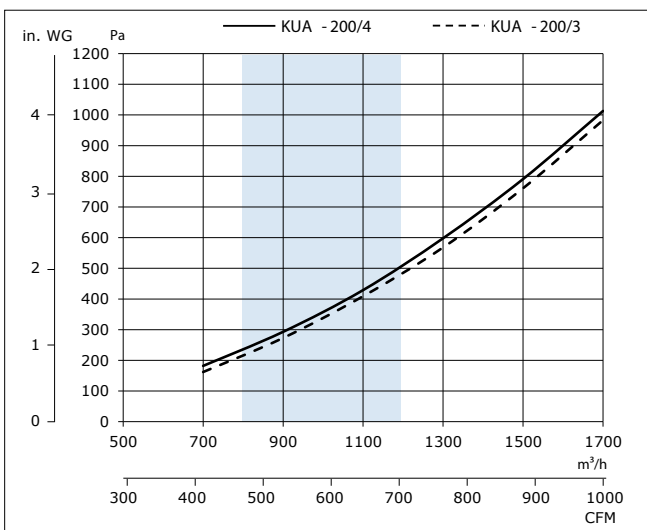

Application restrictions

Do **not** use the product for the following applications or in the following circumstances: polishing applications in combination with grinding, welding or any other application that generate sparks (fibres from polishing or abrasive flap disks are highly flammable and pose a high risk of filter fires when exposed to sparks) | aluminium laser cutting | oil mist | heavy oil mist in welding fume | arc-air gouging | extraction of aggressive fumes and gases (e.g. from acids, from alkaline, from soldering paste containing lithium) | extraction of hot gases (more than 70°C/158°F continuously) | grinding aluminum and magnesium | flame spraying | extraction of cement, saw dust, wood dust etc. | sucking cigarettes, cigars, oiled tissues and other burning particles, objects and acids | explosive environments or explosive substances/gases

Product type	KUA-200
Article no.	<i>refer to Order information</i>
Product category	extraction arms
Version	310818/F

Always check the latest version on www.plymovent.com